

CABLE LENGTH	TOLERANCE*
ALL LENGTHS	+ 4% (OR 50mm) OF LENGTH - 0% (OR 0mm) OF LENGTH WHICHEVER IS GREATER
STRIP LENGTH	TOLERANCE*
0-7mm	±0.5mm
8-29mm	±1.0mm
30-49mm	±2.0mm
50-69mm	±3.0mm
70-100mm	±4.0mm
OVER 100mm	±5.0mm

**\* UNLESS OTHERWISE SPECIFIED**

**CAUTION:**  
RISK OF ELECTRICAL SHOCK  
DO NOT DISCONNECT UNDER LOAD

**SOURCE DRAWING - FOR REFERENCE ONLY**

**NOTES:**

- "\*" INDICATES CABLE LENGTH IN METERS. CONTACT TURCK TO ORDER SPECIFIC LENGTHS.
- CABLE ASSEMBLIES FOR TURCK POWERFAST CONNECTORS ARE RATED AS STAND ALONE. OVERALL CABLE ASSEMBLY RATING IS THE RESPONSIBILITY OF THE CUSTOMER.

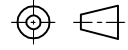
RELATED DOCUMENTS 1. 2. 3. 4.	3RD ANGLE PROJECTION 	THIS DRAWING IS CONFIDENTIAL AND THE PROPERTY OF TURCK INC. USE OF THIS DOCUMENT WITHOUT WRITTEN PERMISSION IS PROHIBITED.	3000 CAMPUS DRIVE MINNEAPOLIS, MN 55441 1-800-544-7769 (763) 553-7300 (763) 553-0708 fax www.turck.us
MATERIAL  SEE SPECIFICATIONS	ALL DIMENSIONS DISPLAYED ON THIS DRAWING ARE FOR REFERENCE ONLY	DRFT RDS DATE 03/27/14 APVD E.S. SCALE 1=2.7 UNIT OF MEASUREMENT <b>MILLIMETER [ INCH ]</b>	DESCRIPTION RSM 44 HANQ4/2-1672-*M IDENTIFICATION NO. REV G
FINISH  SEE SPECIFICATIONS	CONTACT TURCK FOR MORE INFORMATION	DO NOT SCALE THIS DRAWING	FILE: 777033173 SHEET 1 OF 1

G	UPDATED GRN CONDUCTOR TO GRN/YEL PER ECO	TV	12/18/17	60964
REV	DESCRIPTION	BY	DATE	ECO NO.